

1 2 3 4 5 6 7 8

REVISIONS			
ISS	ZONE	DESCRIPTION	PER REQUEST DATE
B	A-1	NO.3 WAS CHANGED	RD-DM90032102C\03-21-01

業務部

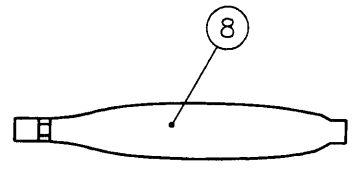
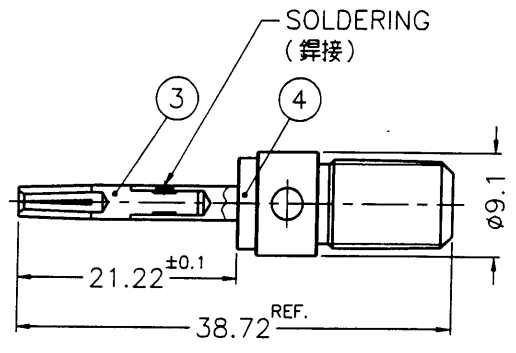
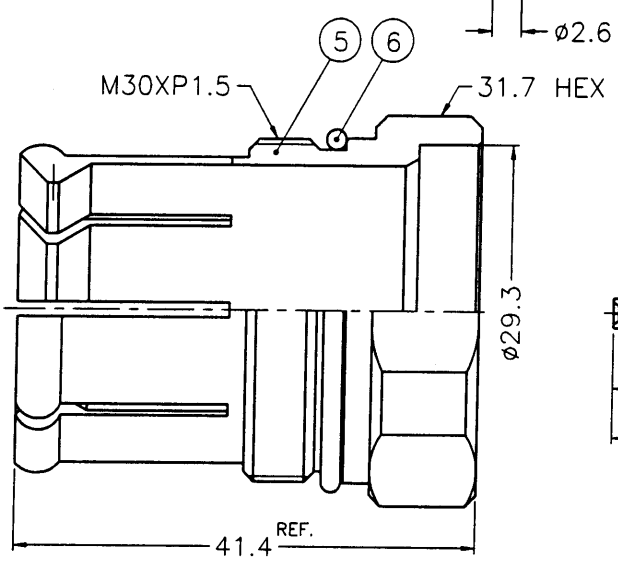
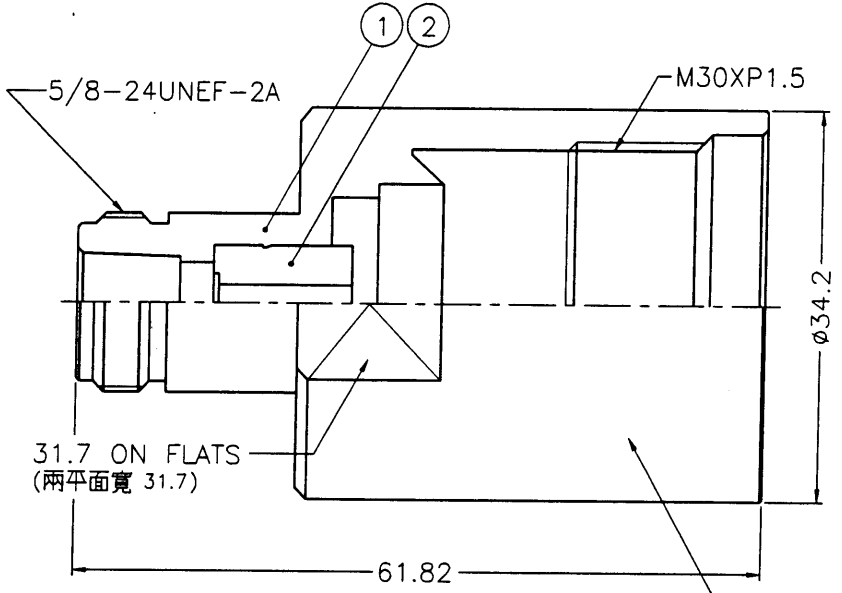
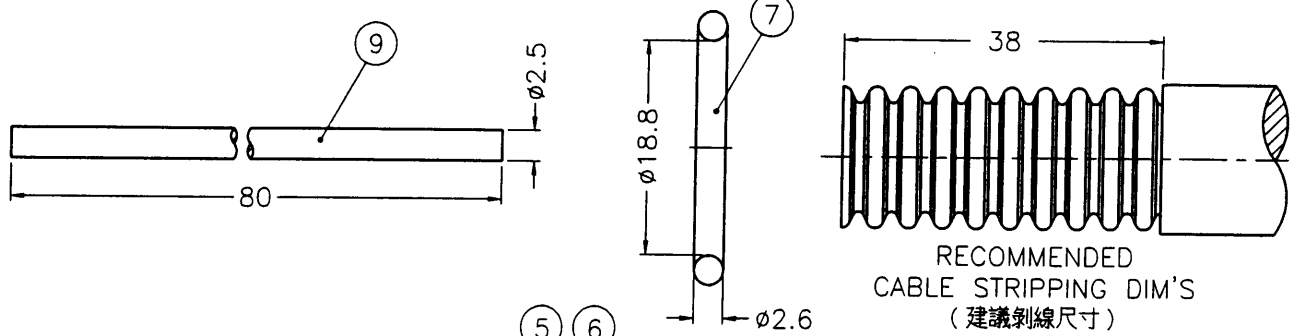

- NOTES: FINISH (PLATING THICKNESS IN MICRO-INCHES)
- BRASS PER QQ-B-626
 - ALBALOY PLATING (COPPER-TIN-ZINC)
 - SILVER PL. 200 MIN. THICK OVER COPPER STRIKE
 - TEFLON MIL-P-19468
 - NICKEL PL. 100 MIN. THICK OVER COPPER STRIKE
 - SILICONE GREASE PER POLYTEX 55-M OR EQUIVALENT
 - PHOSPHOR BRONZE PER QQ-B-750

STAMP (IF ANY)
噴字 (若有要求)



NO.	DESCRIPTION	MATERIAL	FINISH	Q'TY	DRAWING NO.
9	TOOL BAR	S45C		1	N87070303-11
8	LUBRICATOR			1	N87070302-11
7	GASKET	SILICONE	RED	1	GS-24/188XD26
6	GASKET	SILICONE	RED	1	GS-304/27XD17
5	NUT			1	N87070303-7
4	CONTACT PIN			1	N6141G1-34S-2
3	CONTACT PIN			1	N6141G1-34S-1-B
2	INSULATOR		NATURAL	1	N87070303-3
1	BODY			1	N6141G1-1-7/8A

DIMENSIONS ARE IN MILLIMETERS
UNLESS OTHERWISE SPECIFIED TOLERANCES

0.5-6 = ±0.2
6-30 = ±0.4
30-120 = ±0.6
120-315 = ±1
315-1000 = ±1.6
1000-2000 = ±2.4

PART NO.	
APPROVED	DATE 03-21-01'
CHECKED	DATE 03-21-01'
DRAWN	DATE 03-21-01'

Amphenol - Kai Jack	
TAINAN TAIWAN	
TITLE	N CLAMP JACK (FOR ANDREW 7/8" LDF5-50A HELIAX CABLE)
DRAWING NO.	KJ-N6141G1-N/NTS-7/8A-50
FILE NO.	F:\DWG\N\6141G1\78A-50\NNTS

F
E
D
C
B
A

F
E
D
C
B
A

1 2 3 4 5 6 7 8 RDBDR11883.